

CUT KNURLING TOOL C602

DISCONTINUED MODEL

AVAILABLE UNTIL 2022-06-30



KNURLING PROFILE ON WORKPIECE (DIN 82):

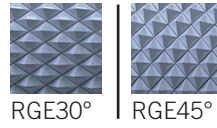

SELECTION OF KNURLING WHEELS (DIN 403):

2x AA | 1x BL15°
1x BR15°

PRODUCT FEATURES	Order no. (right-hand version)	Order no. (left-hand version)	Model	Workpiece Ø [mm]	Knurling wheel (Ø x w x b) [mm]	Dimensions [mm]					
						a	b	c	d	e	f
<ul style="list-style-type: none"> developed for minimal installation space and maximum stability designed for smallest workpiece diameters easy fine adjustment of the knurl carrier 	32000006 <input checked="" type="checkbox"/>	32000005	C602-10	1,5 – 12	8.9 x 2.5 x 4	10	10	106	29.7	29.4	24.3
	32000008 <input checked="" type="checkbox"/>	32000007	C602-12	1,5 – 12	8.9 x 2.5 x 4	12	12	106	29.7	29.4	24.3

Available from stock

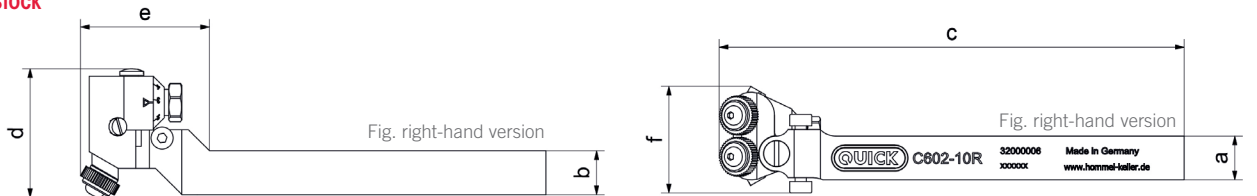

NEW CUT KNURLING TOOL C602



KNURLING PROFILE ON WORKPIECE (DIN 82):

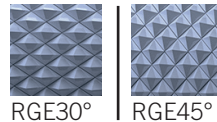

SELECTION OF KNURLING WHEELS (DIN 403):

2x AA | 1x BL15°
1x BR15°

PRODUCT FEATURES	Order no. (right-hand version)	Order no. (left-hand version)	Model	Workpiece Ø [mm]	Knurling wheel (Ø x w x b) [mm]	Dimensions [mm]					
						a	b	c	d	e	f
<ul style="list-style-type: none"> optimized for swiss type lathe applications knurl carrier are flush with outer edge of shank optimized tool positioning: upper edge of shank = center height easy fine adjustment of the knurl carrier designed for smallest workpiece diameters user-friendly handling 	32000363 <input checked="" type="checkbox"/>	32000364	C602-10	1.5 – 12	8.9 x 2.5 x 4	10	10	100	30	20.2	22.7
	32000365 <input checked="" type="checkbox"/>	32000366	C602-12	1.5 – 12	8.9 x 2.5 x 4	12	12	100	30	20.2	23.3
	32000244 <input checked="" type="checkbox"/>	32000245	C602-16	1.5 – 12	8.9 x 2.5 x 4	16	12	100	30	20.2	27
	32000269 <input checked="" type="checkbox"/>	32000270	C602-10	3 – 50	14.5 x 3 x 5	10	10	107	31.5	27	29.5
	32000024 <input checked="" type="checkbox"/>	32000024	C602-12	3 – 50	14.5 x 3 x 5	12	12	107	31.5	27	29.5
	32000252 <input checked="" type="checkbox"/>	32000253	C602-16	3 – 50	14.5 x 3 x 5	16	12	107	31.5	27	30.7

Available from stock

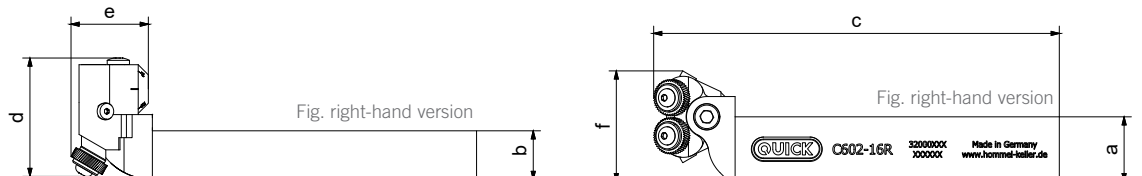

NEW

CUT KNURLING TOOL C602



KNURLING PROFILE ON WORKPIECE (DIN 82):

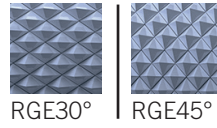

SELECTION OF KNURLING WHEELS (DIN 403):

2x AA | 1x BL15°
1x BR15°

PRODUCT FEATURES

- developed for minimal installation space and maximum stability
- designed for smallest workpiece diameters
- easy fine adjustment of the knurl carrier

Item no. (right-hand version)	Item no. (left-hand version)	Model	Workpiece Ø [mm]	Knurling wheel (Ø x w x b) [mm]	Dimensions [mm]					
					a	b	c	d	e	f
32000282 <input checked="" type="checkbox"/>	32000281	C602-16	5 - 250	21.5 x 5 x 8	16	20	143	69.4	56	50
32000021 <input checked="" type="checkbox"/>	32000086	C602-20	5 - 250	21.5 x 5 x 8	20	20	143	69.4	56	50
32000065 <input checked="" type="checkbox"/>	32000087	C602-25	5 - 250	21.5 x 5 x 8	25	25	143	69.4	56	50

Available from stock

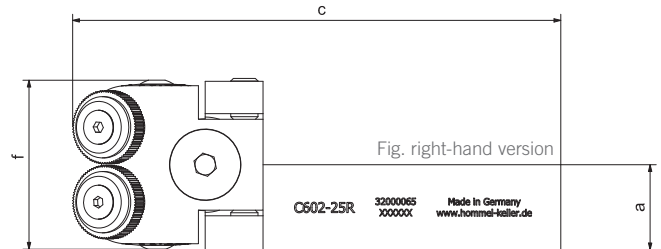
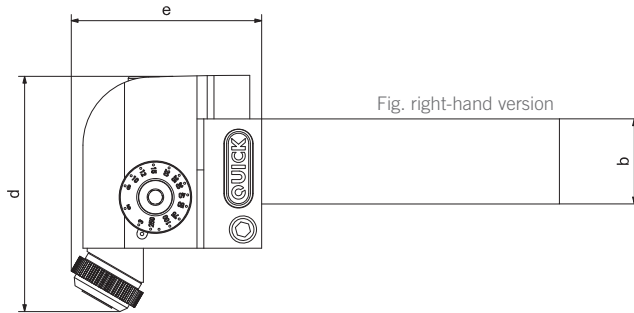

SPARE PARTS C602

E-KIT C602

Item no.	Knurling wheel (Ø x w x b) [mm]	
22BHR0506	8.9 x 2.5 x 4	
22BHR0507	14.5 x 3 x 5	
22BHR0508	21.5 x 5 x 8	

SHANK ASSEMBLED C602 - NEW

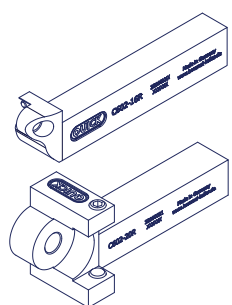
Item no. (right-hand version)	Item no. (left-hand version)	Description	
22BHR0709	22BHR0710	shank 10 x 10	
22BHR0706	22BHR0705	shank 12 x 12	
22BHR0658	22BHR0660	shank 16 x 12	
22BHR0743	22BHR0742	shank 16 x 20	
22BHR0330	22BHR0329	shank 20 x 20	
22BHR0342	22BHR0341	shank 25 x 25	

HEAD ASSEMBLED C602 - NEW

Item no. (for knurl holder Ø 8,9)	Item no. (for knurl holder Ø 14,5)	Item no. (for knurl holder Ø 21,5)	Description	
22BHR0662	22BHR0237	—	shank 10 x 10	
22BHR0662	22BHR0237	—	shank 12 x 12	
22BHR0662	22BHR0237	—	shank 16 x 16	
—	—	22BHR0620	shank 16 x 20	
—	—	22BHR0620	shank 20 x 20	
—	—	22BHR0620	shank 25 x 25	