

CHAMFERS TOOLS

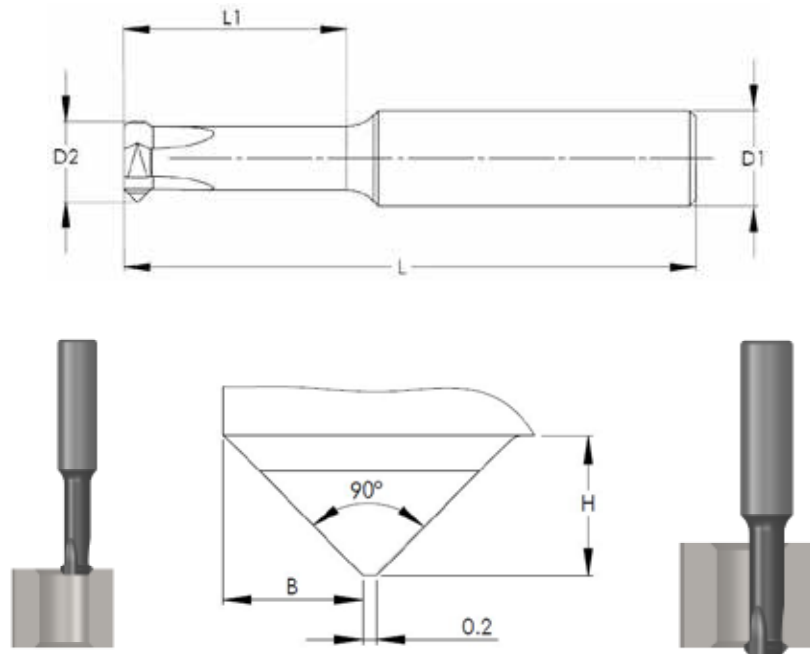

L1-SHORT

	ORDERING CODE	D1	D2	L1	H	B	α	NO. OF FLUTES	L
1	CMP03015L4 P90	3	1.5	4	0.3	0.4	90°	3	39
2	CMP03020L5 P90	3	2.0	5	0.4	0.5	90°	3	39
3	CMP03025L6 P90	3	2.5	6	0.5	0.6	90°	3	39
4	CMP04031L8 P90	4	3.1	8	0.6	0.6	90°	3	51
5	CMP04039L10 P90	4	3.9	10	0.8	0.9	90°	3	51
6	CMP06045L11 P90	6	4.5	11	1.1	1.2	90°	3	58
7	CMP06049L12 P90	6	4.9	12	1.1	1.2	90°	3	58
8	CMP06059L14 P90	6	5.9	14	1.5	1.6	90°	3	58
9	CMP08079L20 P90	8	7.9	20	1.6	1.7	90°	3	64

L1-LONG

	ORDERING CODE	D1	D2	L1	H	B	α	NO. OF FLUTES	L
1	CMP04031L12 P90	4	3.1	12	0.6	0.6	90°	3	51
2	CMP04039L16 P90	4	3.9	16	0.8	0.9	90°	3	51
3	CMP06049L20 P90	6	4.9	20	1.1	1.2	90°	3	58
4	CMP06059L24 P90	6	5.9	24	1.5	1.6	90°	3	58
5	CMP08079L30 P90	8	7.9	30	1.6	1.7	90°	3	64